

SR03

Fast response second class pyranometer

SR03 is the fastest ISO 9060 second class compliant pyranometer available. Due to major advances in thermopile sensing technology, SR03 achieves a 95 % response time in less than 3 seconds. SR03 is optimally suited for PV system performance monitoring, where long-term stability and synchronous response time between the PV module / array and pyranometer are required.



Figure 1 SR03 fast response second class pyranometer



Figure 2 pyranometer in use with LI19 read-out unit

Introduction

SR03 is a solar radiation sensor that can be applied in general observations. It measures the solar radiation received by a plane surface from a field of view angle of 180° . This quantity, expressed in W/m^2 , is called "hemispherical" solar radiation. Contrary to photodiode-based instruments, SR03 has a spectrally flat response across the full solar spectrum.

SR03 pyranometer is used for general meteorological observations, building physics and solar collector testing. However, because of its fast response time, less than 3 seconds, it is ideally suited for PV applications, where it will match the response time of the panels more closely than other pyranometer models. Use on ships and airplanes in conjunction with tilt sensors is also a possibility.

Operation

Using SR03 is easy. It can be connected directly to commonly used data logging systems. The irradiance in W/m^2 is calculated by dividing the SR03 output, a small voltage, by the sensitivity. This sensitivity is provided with SR03 on its calibration certificate.

Uncertainty evaluation

The uncertainty of a measurement under outdoor conditions depends on many factors. Guidelines for uncertainty evaluation according to the "Guide to Expression of Uncertainty in Measurement" (GUM) can be found in our manuals. We provide spreadsheets to assist in the process of uncertainty evaluation of your measurement.

Suggested use

- PV system performance monitoring
- on buoys
- on aircrafts

SR03 design

SR03 pyranometer employs a new generation fast thermal sensor with black coating, a single glass dome and an anodised aluminium body.

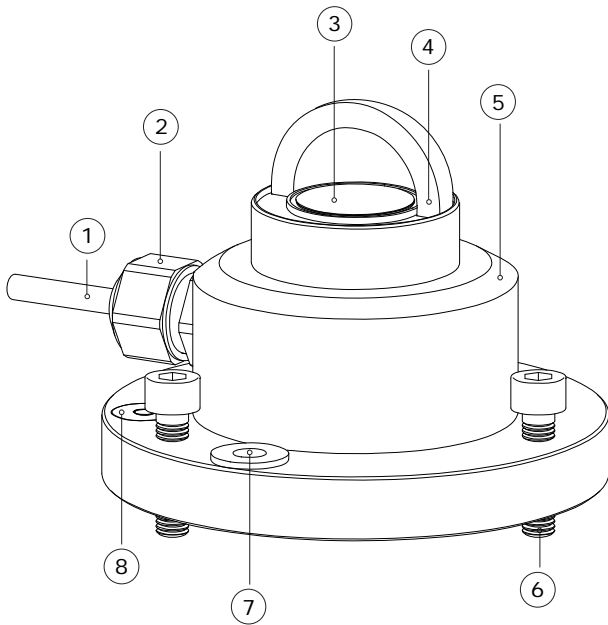

Figure 3 overview of SR03:

(1) cable, (2) cable gland, (3) thermal sensor with black coating, (4) glass dome, (5) sensor body, (6) levelling feet, (7) mounting hole, (8) bubble level

Choosing the right instrument

Pyranometers are subject to classification in three classes according to ISO 9060. From second class to first class and from first class to secondary standard, the achievable accuracy improves by a factor 2. Measurement accuracy does not only depend on instrument properties, but also on measurement conditions. A very accurate instrument will quickly underperform without a regular schedule of maintenance.

Our pyranometer [selection guide](#) assists you in choosing the right instrument. Whatever your application is: Hukseflux offers the highest accuracy in every class at the most attractive price level.

Standards

Applicable instrument classification standards are ISO 9060 and WMO-No. 8. Calibration is according to ISO 9847. PV related standards are ASTM E2848 and IEC 61724.

SR03 specifications

Measurand	hemispherical solar radiation
ISO classification	second class pyranometer
Calibration uncertainty	< 1.8 % (k = 2)
Response time (95 %)	< 3 s
Calibration traceability	to WRR
Spectral range	285 to 3000 x 10 ⁻⁹ m
Sensitivity (nominal)	15 x 10 ⁻⁶ V/(W/m ²)
Rated operating temperature range	-40 to +80 °C
Temperature response	< ± 3 % (-10 to +40 °C)
Standard cable length	5 m

Options

- longer cable, in multiples of 5 metres
- sun screen
- SR03-LI19, including readout unit [LI19](#)

See also

- SR03-TR fast response pyranometer with 4-20 mA transmitter
- alternative instruments: [SR11](#), [SR12](#) and [SR20](#) pyranometers for higher accuracy measurements
- view our complete [product range of solar sensors](#)

About Hukseflux

Hukseflux Thermal Sensors offers measurement solutions for the most challenging applications. We design and supply sensors as well as test & measuring systems, and offer related services such as engineering and consultancy. With our laboratory facilities, we provide testing services including material characterisation and calibration. Our main area of expertise is measurement of heat transfer and thermal quantities such as solar radiation, heat flux and thermal conductivity. Hukseflux is ISO 9001:2008 certified. Hukseflux sensors, systems and services are offered worldwide via our office in Delft, the Netherlands and local distributors.

Interested in this product?
E-mail us at: info@hukseflux.com