

SR22

Secondary standard pyranometer with quartz domes – extended spectral range

SR22 is a solar radiation sensor of the highest category in the ISO 9060 classification system: secondary standard. On top of the features and benefits of the successful SR20 pyranometer, SR22 has domes made of high-quality quartz, resulting in an extended spectral range. Covering the full solar spectrum, SR22's extended spectral range potentially offers lower measurement- and calibration uncertainties compared to pyranometers with glass domes. SR22 is typically used in combination with VU01 ventilation unit in high-accuracy climatological networks.



Figure 1 SR22 secondary standard pyranometer



Figure 2 SR22 sensor combined with VU01 ventilation unit

Introduction

SR22 measures the solar radiation received by a plane surface, in W/m^2 , from a 180° field of view angle. This ISO 9060 secondary standard pyranometer enables users to attain the highest measurement accuracy and offers the widest spectral range commercially available. SR22 has an onboard temperature sensor. When using SR22, additional ventilation is recommended. SR22 is typically combined with ventilation unit VU01.

Extended spectral range

On top of the features and benefits of SR20 pyranometer, SR22 has an inner and outer dome made of high-quality quartz. This results in SR22's spectral range of 190 to 4000×10^{-9} m. SR22 covers the full solar spectrum, including the part between 3000 to 4000×10^{-9} m, which is not measured by pyranometers with glass domes.

Measurement accuracy

In order to improve overall measurement accuracy, Hukseflux effectively targeted two major sources of measurement uncertainty: calibration and “zero offset a”.

The initial calibration uncertainty is less than 1.7 %. The “zero offset a” specification of SR22 is 5 W/m² unventilated. Ventilated (with VU01) it is just 2.5 W/m².

Demanding applications

SR22’s low temperature dependence makes it an ideal candidate for use under very cold and very hot conditions. The temperature dependence of every individual instrument is tested and supplied as a second degree polynomial. This information can be used for further reduction of temperature dependence during post-processing.

SR22 design

SR22 pyranometer uses a state of the art thermopile sensor with black coated surface, two quartz domes of the highest quality and an anodised aluminium body. The connector, desiccant holder and sun screen fixation are very robust and designed for industrial use. All parts are specified for use across SR22’s entire rated operating temperature range.

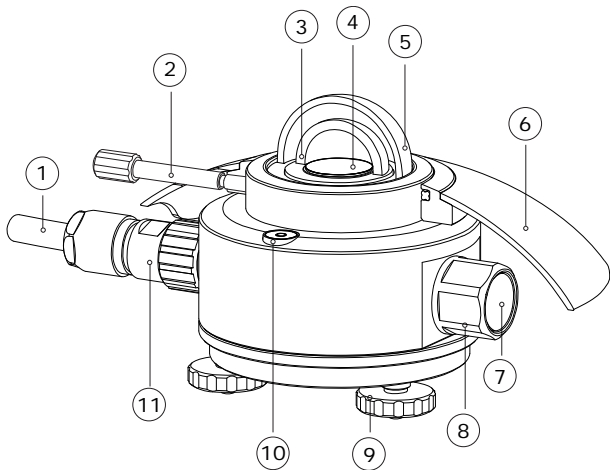

Figure 3 overview of SR22:

(1) cable, (2) fixation of sun screen, (3) inner quartz dome, (4) thermal sensor with black coating, (5) outer quartz dome, (6) sun screen, (7) humidity indicator, (8) desiccant holder, (9) levelling feet, (10) bubble level, (11) connector

Uncertainty evaluation

The uncertainty of a measurement under outdoor conditions depends on many factors. Guidelines for uncertainty evaluation according to the “Guide to Expression of Uncertainty in Measurement” (GUM) can be found in our manuals. We provide spreadsheets to assist in the process of uncertainty evaluation of your measurement.

Standards

Applicable instrument classification standards are ISO 9060 and WMO-No. 8. Included in delivery as required by ISO 9060: test certificates for temperature response and directional response. Calibration is according to ISO 9847. PV related standards are ASTM E2848 and IEC 61724.



Figure 4 the inner and outer quartz domes of SR22 allow users to utilise SR22’s extended spectral range

Choosing the right instrument

Pyranometers are subject to classification in three classes according to ISO 9060.

From second class to first class and from first class to secondary standard, the achievable accuracy improves by a factor 2.

Measurement accuracy does not only depend on instrument properties, but also on measurement conditions. A very accurate instrument will quickly underperform without a regular schedule of maintenance.

Our pyranometer [selection guide](#) assists you in choosing the right instrument.

Whatever your application is: Hukseflux offers the highest accuracy in every class at the most attractive price level.

Suggested use

- scientific climatological observations
- reference instrument for comparison
- extreme climates (tropical / polar)



Figure 5 SR22 side view

See also

- [SR20](#) secondary standard pyranometer
- [SR20-D2](#) digital secondary standard pyranometer with Modbus RTU and 4-20 mA output
- [SR25](#) secondary standard pyranometer with sapphire outer dome
- view our complete [product range of solar sensors](#)

SR22 specifications

Measurand	hemispherical solar radiation
ISO classification	secondary standard pyranometer
Calibration uncertainty	< 1.7 % (k = 2)
Zero offset a	5 W/m ² unventilated
Zero offset a	2.5 W/m ² ventilated
Calibration traceability	to WRR
Spectral range	190 to 4000 x 10 ⁻⁹ m
Spectral selectivity	< ± 2 % (0.35 to 1.5 x 10 ⁻⁶ m)
Sensitivity (nominal)	15 x 10 ⁻⁶ V/(W/m ²)
Rated operating temperature range	-40 to +80 °C
Temperature response	< ± 1 % (-10 to +40 °C) < ± 0.4 % (-30 to +50 °C) with correction in dataprocessing report included
Temperature response test of individual instrument	report included
Directional response test of individual instrument	report included
Temperature sensor	Pt100 or 10 kΩ thermistor
Heater	1.5 W at 12 VDC
Standard cable length	5 m

Options

- longer cable, in multiples of 5 metres
- ventilated with [VU01](#) ventilation unit

About Hukseflux

Hukseflux Thermal Sensors offers measurement solutions for the most challenging applications. We design and supply sensors as well as test & measuring systems, and offer related services such as engineering and consultancy. With our laboratory facilities, we provide testing services including material characterisation and calibration. Our main area of expertise is measurement of heat transfer and thermal quantities such as solar radiation, heat flux and thermal conductivity. Hukseflux is ISO 9001:2008 certified. Hukseflux sensors, systems and services are offered worldwide via our office in Delft, the Netherlands and local distributors.

Interested in this product?
E-mail us at: info@hukseflux.com

SR22 secondary standard pyranometer – with quartz domes

Nowadays, the best pyranometers are made by Hukseflux Thermal Sensors. This overview of features and benefits of SR22 gives you some of the reasons why! Whatever your application is, Hukseflux offers the highest accuracy in every class at the most attractive price level.



Best measurement accuracy

- lowest zero offsets
- lowest calibration uncertainty
- best temperature dependence

- only Hukseflux includes all ISO required reports with every individual sensor
 - temperature response testing from -30 to 50 °C
 - full directional response testing

Best paperwork

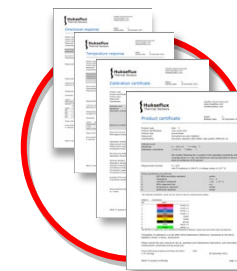

Best connector

- interchangeable cables
- IP67 grade
- for industrial use

Best desiccant cartridge

- visible indicator of instrument health
- rugged aluminium design
- serviceable by user

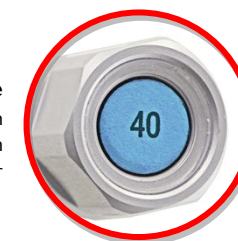

Best sun screen

- sealed
- corrosion protection of body
- no dry-cooking of bubble level

Best humidity protection

- wrench-operated
- o-ring compressed to spec
- desiccant service interval > 2 years

